



Doosan Infracore
Construction Equipment

DX225LC SLR

Engine Power : SAE J1349, net 110kW (148HP)@1,900rpm

Operational Weight : 23,800kg (52,470 lb)

Bucket capacity(SAE) : 0.39m³ (0.51 cu.yd)



DIMENSIONS

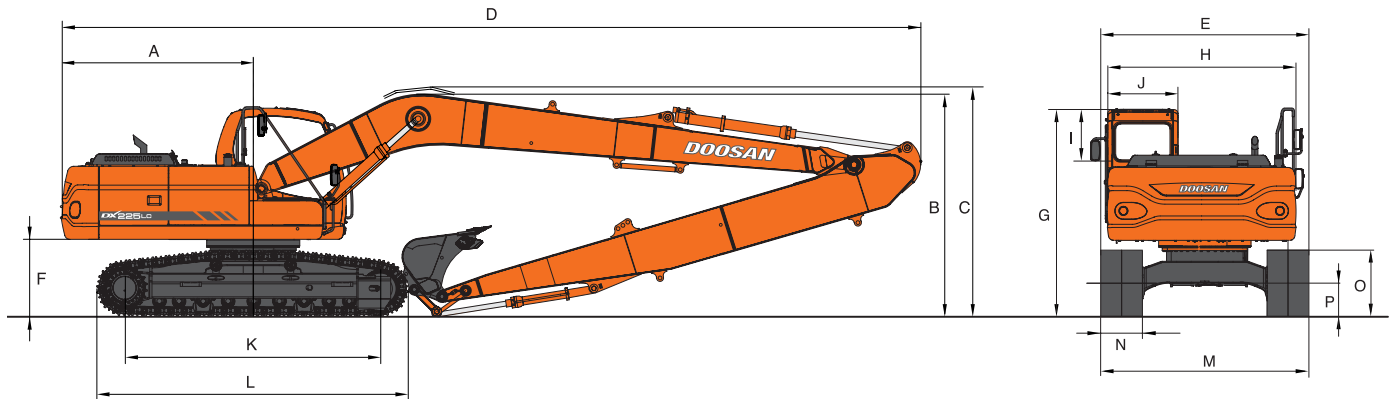

* DIMENSIONS

Boom type (One piece)	8,500mm(27'11")
Arm type	6,200mm(20'4")
Bucket Capacity (pcsa)	0.39m ³
A Tail Swing Radius	2,750mm(9')
B Shipping Height (Boom)	3,175mm (10' 5")
C Shipping Height (Hose)	3,254mm (10' 8")
D Shipping Length	12,317mm(40' 5")
E Shipping Width	2,990mm(9' 10")
F C/Weight Clearance	1,055mm(3' 6")
G Height Over CAB.	2,975mm(9' 9")
H House Width	2,710mm(8' 11")
I CAB. Height above House	845mm(2' 9")
J CAB. Width	960mm(3' 2")
K Tumbler Distance	3,650mm(11' 12")
L Track Length	4,445mm(14' 7")
M Undercarriage Width	3,190mm(10' 6")
N Shoe Width	800mm(2' 7")
O Track Height	947mm(3' 1")
P Car Body Clearance	480mm(1' 7")

* DIGGING FORCE (ISO)

Bucket (PCSA)	0.39m ³
Digging force	10,000 kgf
	98.1 kN
	22,046 lbf
Arm	6,200mm
Digging force	5,980 kgf
	58.7 kN
	13,183 lbf

At power boost (ISO)

* WEIGHT

Boom 8,500 mm (27'11") • Arm 6,200 mm (20'4") • Bucket SAE 0.39 m³ (0.51 yd³)

	Shoe width	Operating weight	Ground pressure (kgf/cm ²)
Triple Grouser	600 mm (2')	23,200 kg (51,147 lb)	0.49 kgf/cm ² (48.1 kpa, 7.0psi)
	700 mm (2'4")	23,500 kg (51,809 lb)	0.43 kgf/cm ² (42.2 kpa, 6.1psi)
	800 mm (2'8")	23,800 kg (52,470 lb)	0.38 kgf/cm ² (37.3 kpa, 5.4 psi)
	900 mm (2'11")	24,100 kg (53,131 lb)	0.33 kgf/cm ² (32.4 kpa, 4.7 psi)

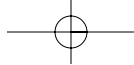

WORKING RANGES

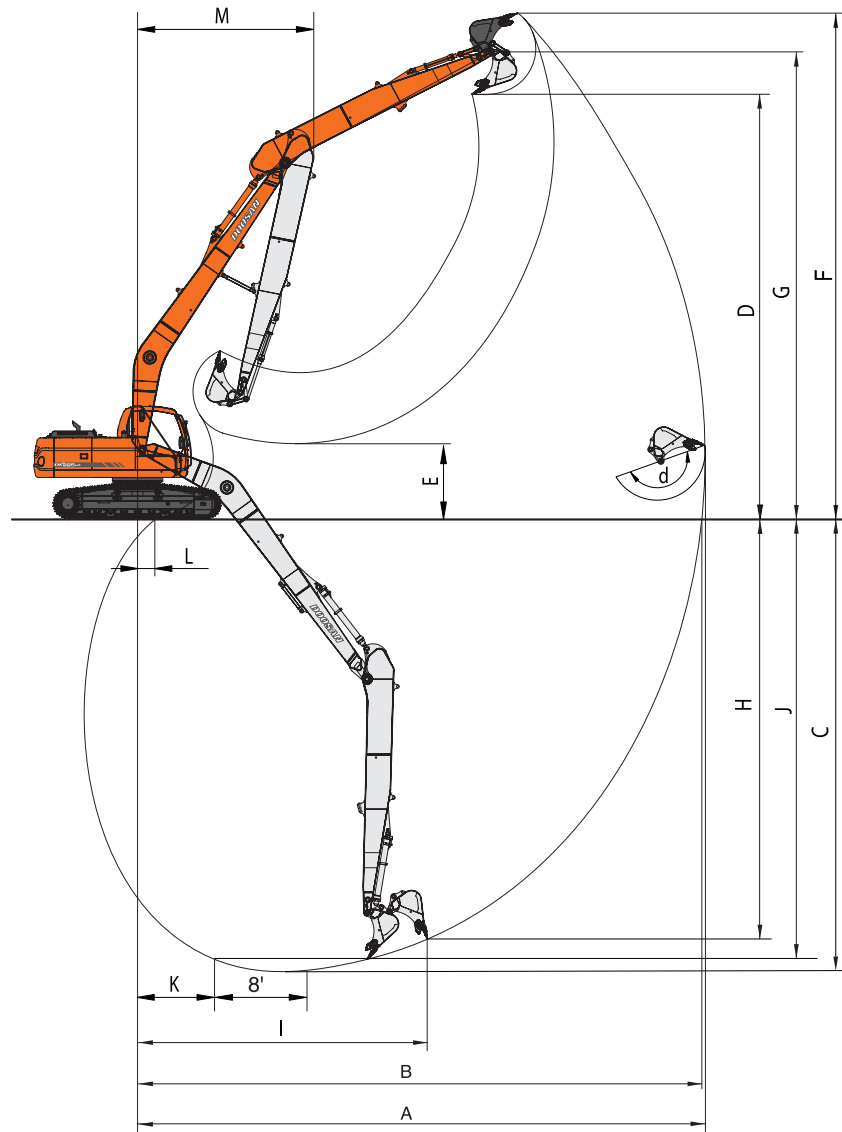

* WORKING RANGE

Boom length	8,500mm(27'11")
Arm type	6,200mm(20'4")
Bucket Capacity (pcsa)	0.39m ³
A. Max. digging reach	15,379mm(50'5")
B. Max. digging reach at ground level	15,268mm(50'1")
C. Max. digging depth	11,661mm(38'3")
D. Max. dumping height	11,148mm(36'7")
E. Min. dumping height	2,009mm(6'7")
F. Max. digging height	13,403mm(44')
G. Max. bucket pin height	12,380mm(40'7")
H. Max. vertical wall depth	9,729mm(31'11")
I. Max. radius vertical	10,064mm(33')
J. Max. digging depth(8' level)	11,561mm(37'11")
k. Min. radius 8' line	4,854mm(15'11")
L. Min. digging reach	196mm(8")
M. Min. swing radius	4,714mm(15'6")
d. Bucket angle (deg)	166°

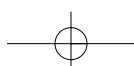

LIFTING CAPACITY

DX225LC SLR

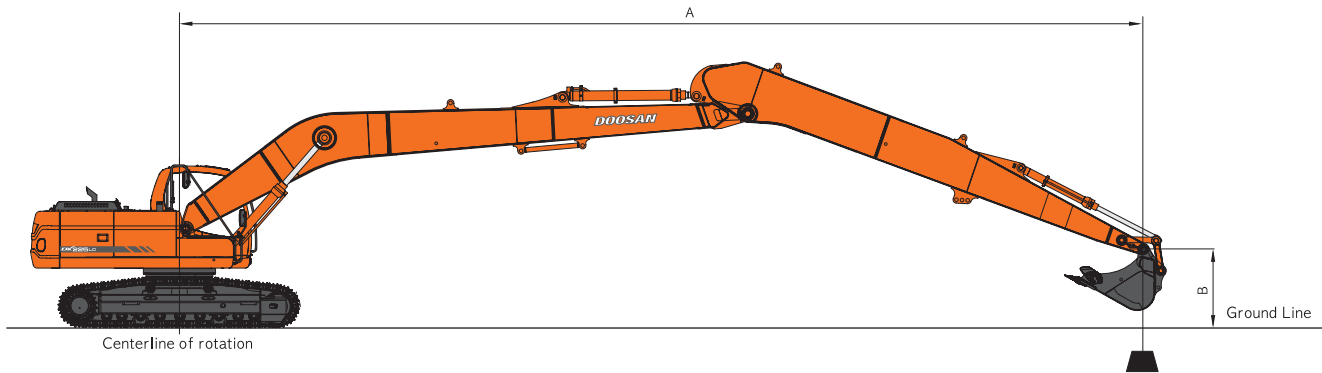

Boom : 8,500mm(27'11") Arm : 6,200mm(20'4") Bucket : SAE 0.39m³(0.51yd³) CECE 0.35m³ Shoe : 800mm(2'7")

Metric

Unit : 1,000kg

A(m)	2		3		4		5		6		7		8		9		10		11		12		13		14		Max. Reach								
	👤	👤	👤	👤	👤	👤	👤	👤	👤	👤	👤	👤	👤	👤	👤	👤	👤	👤	👤	👤	👤	👤	👤	👤	👤	👤	👤	A(m)							
12																												*1.02	*1.02	9.70					
11																													*0.98	*0.98	10.66				
10																		*1.67	*1.67										*0.95	*0.95	11.46				
9																		*2.28	*2.28	*2.00	*2.00	*1.12	*1.12						*0.94	*0.94	12.11				
8																		*2.33	*2.33	*2.32	2.30	*1.75	*1.75						*0.94	*0.94	12.66				
7																		*2.42	*2.42	*2.40	2.28	*2.14	1.91	*1.12	*1.12				*0.94	*0.94	13.10				
6																*2.63	*2.63	*2.55	*2.55	*2.49	2.24	*2.44	1.89	*1.65	1.59				*0.96	*0.96	13.46				
5																*3.02	*3.02	*2.85	*2.85	*2.71	2.61	*2.60	2.20	*2.52	1.86	*2.01	1.57		*0.98	*0.98	13.73				
4																		*3.69	*3.69	*3.35	*3.35	*3.09	3.03	*2.89	2.54	*2.74	2.14	*2.61	1.82	*2.30	1.55		*1.01	*1.01	13.92
3																														*1.04	*1.04	14.04			
2																														*1.08	*1.08	14.09			
1																														*1.14	*1.14	14.07			
0 (Ground)																														*1.20	*1.20	13.97			
-1																														*1.27	*1.27	13.80			
-2																															*1.37	*1.37	13.56		
-3																															*1.48	*1.48	13.23		
-4																															*1.62	*1.62	12.82		
-5																															*1.80	*1.80	12.31		
-6																															*2.04	*2.04	11.69		
-7																															*2.38	*2.38	10.95		
-8																															*2.76	*2.76	10.05		
-9																															*2.67	*2.67	8.95		
-10																															*2.46	*2.46	7.53		

Feet

Unit : 1,000lb

A(ft)	10'		15'		20'		25'		30'		35'		40'		45'		Max. Reach																
	👤	👤	👤	👤	👤	👤	👤	👤	👤	👤	👤	👤	👤	👤	👤	👤	👤	A(ft)															
40																														*2.28	*2.28	31.16	
35																															*2.14	*2.14	35.91
30																															*2.08	*2.08	39.46
25																															*2.07	*2.07	42.12
20																															*2.11	*2.11	44.05
15																															*2.18	*2.18	45.34
10																															*2.29	*2.29	46.06
5																															*2.44	*2.44	46.22
0 (Ground)																															*2.64	*2.64	45.84
-5																															*2.91	*2.91	44.89
-10																															*3.27	*3.27	43.35
-15																															*3.79	*3.79	41.14
-20																															*4.56	*4.56	38.14
-25																															*5.88	*5.88	34.16
-30																															*5.84	*5.84	28.77

1. Ratings are based on SAE J1097
2. The load point is a hook located on the back of the bucket.
3. * Rated loads are based on hydraulic capacity.
4. Rated loads do not exceed 87% of hydraulic capacity or 75% of tipping capacity.



: Rating Over Front



: Rating Over Side or 360 degree

TECHNICAL SPECIFICATIONS **DX225LC SLR**

* ENGINE

• Model

Doosan DLo6

• Rated flywheel horse power

110 kW(148 HP) @ 1,900 rpm (SAE J1349, net)

• Piston displacement

5,890 cc (359 cu.in)

* HYDRAULIC SYSTEM

The heart of the system is the e-EPOS (Electronic Power Optimizing System). It allows the efficiency of the system to be optimized for all working conditions and minimizes fuel consumption.

The new e-EPOS is connected to the engine electronic control via a data transfer link to harmonize the operation of the engine and hydraulics.

- The hydraulic system enables independent or combined operations.
- Two travel speeds offer either increased torque or high speed tracking.
- Cross-sensing pump system for fuel savings.
- Auto deceleration system.
- Two operating modes, two power modes.
- Button control of flow in auxiliary equipment circuits.
- Computer-aided pump power control.

• Main pumps

2 variable displacement axial piston pumps
max flow: 2 x 211 ℓ /min (2 X 55.7 US gpm, 2 X 46.4 lmp gpm)

• Pilot pump

Gear pump - max flow: 28.5 ℓ /min (55.7 US gpm, 46.4 lmp gpm)

• Maximum system pressure

Boom/arm/Bucket:
Normal mode: 330 kgf/cm²(324 bar)
Power mode: 350 kgf/cm²(343 bar)
Travel: 330 kgf/cm²(324 bar)
Swing: 270 kgf/cm²(264 bar)

* REFILL CAPACITIES

• Fuel tank

400 ℓ (105.7 US gal, 88 lmp gal)

• Cooling system (Radiator capacity)

24 ℓ (6.3 US gal, 5.3 lmp gal)

• Engine oil

27 ℓ (7.1 US gal, 5.9 lmp gal)

• Swing drive

5 ℓ (1.32 US gal, 1.1 lmp gal)

* HYDRAULIC CYLINDERS

The piston rods and cylinder bodies are made of high-strength steel. A shock absorbing mechanism is fitted in all cylinders to ensure shock-free operation and extend piston life.

Cylinders	Quantity	Bore x Rod diameter x stroke
SLR Bucket	1	95 X 65 X 900 mm(4.7" X 3.1" X 5'4")

* SWING MECHANISM

- An axial piston motor with two-stage planetary reduction gear is used for the swing.
- Increased swing torque reduces swing time.
- Internal induction-hardened gear.
- Internal gear and pinion immersed in lubricant bath.
- The swing brake for parking is activated by spring and released hydraulically.

Swing speed: 0 to 11.0 rpm

* DRIVE

Each track is driven by an independent axial piston motor through a planetary reduction gearbox.

Two levers with control pedals guarantee smooth travel with counter-rotation on demand.

• Travel speed (fast/slow)

5.5/3.0 km/h (3.4/1.9mph)

• Maximum traction force

11,700 / 22,200 kgf (25,794 / 48,942 lbf)

• Maximum grade

35° / 70%

• Final drive (each)

5.4 ℓ (1.43 US gal, 1.2 lmp gal)

• Hydraulic system

330 ℓ (87 US gal, 73 lmp gal)

• Hydraulic tank

240 ℓ (63.4 US gal, 52.8 lmp gal)

* BUCKET

Capacity		Width		Weight	Recommendation
PCSA, heaped	CECE heaped	Without side cutters	With side cutters		8,500mm (27'11") Boom
0.39m ³ (0.51yd ³)	0.35m ³	736mm (2'5")	820mm (2'8")	309 kg (681 lb)	6,200 (20'4") Arm

